

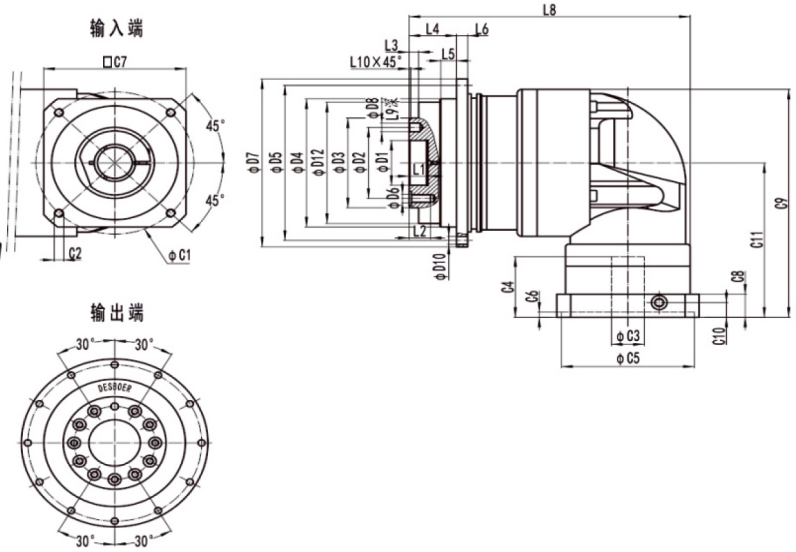

GABRIEL NDR200



(单位: mm)

Reducer Performance Information

	D1	D2	D3	D4	D5	D6	D7	D8	D10	D12	
NDR200 (单节)	80	125	160	200	233	11-M10 × 1.5P	247	10	12 × 9	199.2	
	L1	L2	L3	L4	L5	L6	L8	L9	L10	L10	
NDR200 (单节)	16	22.5	8	50	15	12	334.5	10	1	1	
	C1*	C2*	C3*	C4*	C5*	C6*	C7*	C8*	C9*	C10*	C11*
NDR200 (单节)	215	M12 × 1.75P	≤48	85	180	6	190	29	316	20.75	213.5

*Dimensions based on servo-motor, please contact us for custom made order.

Segment Number		Single Segment					
Ration	i	4	5	7	10	14	20
Rated Output Torque	Nm	1100	1200	1100	900	1100	900
Emergency Stop Torque	Nm	三倍额定输出力矩					
Rated Input Speed	rpm	3000					
Max. Input Speed	rpm	6000					
Ultraprecise Backlash	arcmin	≤2					
Precise Backlash	arcmin	≤4					
Standard Backlash	arcmin	≤6					
Torsional Rigidity	Nm/arcmin	440					
Maximum Bending Moment	Nm	3064					
Max. Axial Force	N	16660					
Service Life	hr	30000(连续运转为15000)					
Efficiency	%	≥95%					
Weight	kg	50.9					
Operating Temperature	°C	-10°C ~ +90°C					
Lubrication		合成润滑油脂					
Protection Class		IP64					
Mounting Position		任意方向					
Noise Level (N1=3000rpm, Non-Loaded)	dB (A)	≤72					
Rotary Inertia	kg · cm ²	68.9				65.6	

★ Maximum output force 60%

▲ Output rotation speed 100rpm

