

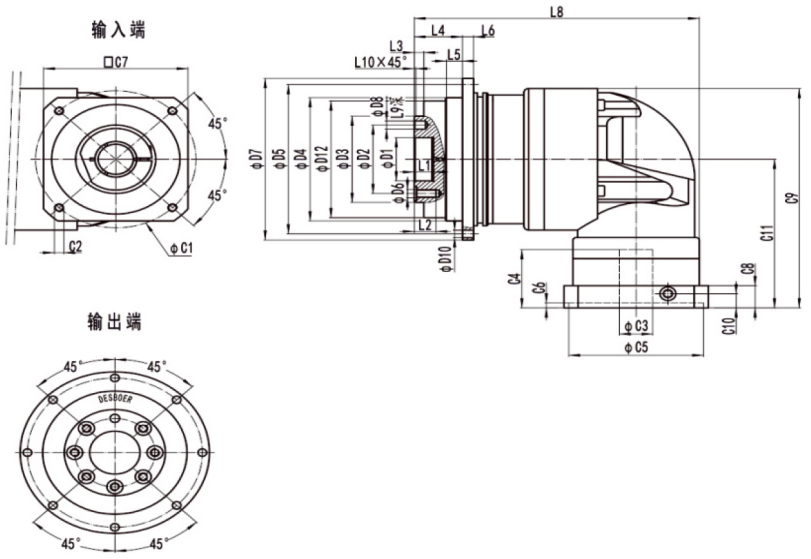

GABRIEL NDR064



(单位: mm)

Reducer Performance Information

NDR064 (单节)	D1	D2	D3	D4	D5	D6	D7	D8	D10	D12	
	L1	L2	L3	L4	L5	L6	L8	L9		L10	
	C1*	C2*	C3*	C4*	C5*	C6*	C7*	C8*	C9*	C10*	C11*
	20	31.5	40	64	79	7-M5×0.8P	86	5	8×4.5		63.2
	8	8	3	19.5	7	4	126	6		0.5	
70	M5×0.8P	≤14/≤16	34	50	7	60	18.5	116.5	14	81.5	

*Dimensions based on servo-motor, please contact us for custom made order.

Segment Number		Single Segment					
Ration	i	4	5	7	10	14	20
Rated Output Torque	Nm	48	60	50	40	42	40
Emergency Stop Torque	Nm	三倍额定输出力矩					
Rated Input Speed	rpm	5000					
Max. Input Speed	rpm	10000					
Ultraprecise Backlash	arcmin	-					
Precise Backlash	arcmin	≤4					
Standard Backlash	arcmin	≤6					
Torsional Rigidity	Nm/arcmin	13					
Maximum Bending Moment	Nm	125					
Max. Axial Force	N	1050					
Service Life	hr	30000(连续运转为15000)					
Efficiency	%	≥95%					
Weight	kg	2.1					
Operating Temperature	°C	-10°C ~ +90°C					
Lubrication		合成润滑油脂					
Protection Class		IP64					
Mounting Position		任意方向					
Noise Level (N1=3000rpm, Non-Loaded)	dB (A)	≤63					
Rotary Inertia	kg·cm ²	0.35				0.07	

★ Maximum output force 60%

▲ Output rotation speed 100rpm

